



# VOC Room Sensor in the BAPI-Stat "Quantum Prime" Style Enclosure

Installation and Operating Instructions

40697\_ins\_BSQPrime\_VOC

rev. 07/22/20

## Identification and Overview

Humans respire Volatile Organic Compounds (VOCs) as well as CO<sub>2</sub>. The BAPI sensor is able to measure these VOCs and indicate when a space is occupied just as well as a CO<sub>2</sub> sensor.

The advantage of the VOC sensor is that it measures air contaminants from other sources besides respiration, such as building materials, cleaners, perfumes and furniture and carpet off-gassing. Using this sensor for Demand Controlled Ventilation then is a way of achieving true indoor air quality, rather than just CO<sub>2</sub> dilution.

A further benefit is that it requires no additional work on your part. That's because the sensor converts the VOC reading to a CO<sub>2</sub> equivalent level. This lets you use Ashrae's CO<sub>2</sub>-based VRP schedule to ventilate.

The new BAPI-Stat "Quantum Prime" unit is available as a VOC sensor alone or as a combination temperature and humidity sensor. The optional display alternates between the measured values and is field adjustable between °F or °C. The VOC level is indicated as "Good, Fair or Poor" by three green, yellow and red LEDs on the front of the unit.

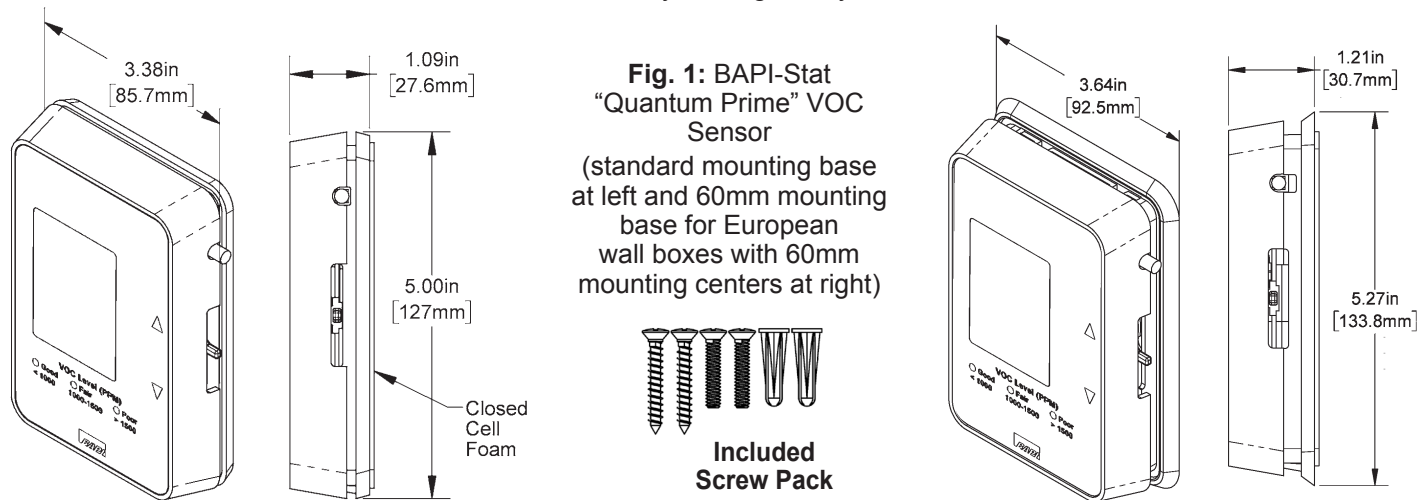

## Specifications

### Power for 0 to 5 VDC Outputs:

9 to 35 VDC, 50mA Peak @ 24VDC  
(9 to 24 VDC recommended)

### Power for 0 to 10 VDC Outputs:

15 to 35 VDC, 50mA Peak @ 24VDC  
(15 to 24 VDC recommended)

**VOC Sensor:** Micro-machined Metal Oxide

**Humidity Sensor:** Capacitive Polymer, ±2% RH Accuracy

**Temperature Sensor:** Thermistor or RTD

### Operating Environment:

32 to 122°F (0 to 50°C) • 0 to 95%, RH non-condensing

**Enclosure Material and Rating:** ABS Plastic, UL94V-0

**VOC Detection Range:** 0 to 2,000 CO<sub>2</sub> PPM equivalent

**Start-Up Time:** 15 Minutes

**Response Time:** Less Than 60 Seconds (after Start-Up Time)

### Mounting:

Standard 2"x4" junction box, European junction box or drywall mount (screws provided)

### LCD Display:

Major Display: Displays CO<sub>2</sub> PPM Equivalent  
Minor Display: Displays Temp & %RH when present

### Measurement Offsets: (Field Adjustable)

±5° (F or C) in 0.1° increments  
±5% RH in 0.1% RH increments  
±100 ppm CO<sub>2</sub> Equivalent in 1 ppm increments

### LED VOC Level Indicator:

Good, Green < 1,000 PPM  
Fair, Orange = 1,000 to 1,500 PPM  
Poor, Red > 1,500 PPM

**Certifications:** RoHS

**Warranty Period:** 5 Years from manufacture date

Note: The VOC contaminant output (CO<sub>2</sub>/VOC terminal on the circuit card) is scaled for 0 to 2,000ppm equivalent CO<sub>2</sub> for use in an ASHRAE Standard 62.1 Demand Control Ventilation algorithm. The display shows contamination to an equivalent 5,000ppm CO<sub>2</sub>. This allows additional troubleshooting for a building manager to determine if there is a very large VOC contamination when the transmitted output is at its maximum value

Specifications subject to change without notice.



# VOC Room Sensor in the BAPI-Stat “Quantum Prime” Style Enclosure

Installation and Operating Instructions

40697\_ins\_BSQPrime\_VOC

rev. 07/22/20

## Mounting

Mounting hardware is provided for both junction box and drywall installation (junction box installation shown).

Note: Screw the 1/16" Allen lock-down screw into the base to open the case. Back out the lock-down screw to secure the cover.

### Junction Box

1. Pull the wire through the wall and out of the junction box, leaving about six inches free.
2. Pull the wire through the hole in the base plate.
3. Secure the plate to the box using the #6-32 x 5/8 inch mounting screws provided.
4. Terminate the unit according to the guidelines in the Termination section. (page 3)
5. Mold the foam on the unit's base to the wire bundle to prevent drafts. (see note below)
6. Attach Cover by latching it to the top of the base, rotating the cover down and snapping it into place.
7. Secure the cover by backing out the lock-down screw using a 1/16" Allen wrench until it is flush with the bottom of the cover.

### Drywall Mounting

1. Place the base plate against the wall where you want to mount the sensor. Mark out the two mounting holes and the area where the wires will come through the wall.
2. Drill two 3/16" holes in the center of each marked mounting hole, DO NOT punch the holes or the drywall anchors will not hold. Insert a drywall anchor into each hole.
3. Drill one 1/2" hole in the middle of the marked wiring area.
4. Pull the wire through the wall and out of the 1/2" hole, leaving about six inches free. Pull the wire through the hole in the base plate.
5. Secure the base to the drywall anchors using the #6 x 1 inch mounting screws provided.
6. Terminate the unit according to the guidelines in the Termination section. (page 3)
7. Mold the foam on the unit's base to the wire bundle to prevent drafts. (see note below)
8. Attach cover by latching it to the top of the base, rotating the cover down and snapping it into place.
9. Secure the cover by backing out the lock-down screw using a 1/16" Allen wrench until it is flush with the bottom of the cover.

NOTE: In any wall-mount application, the wall temperature and the temperature of the air within the wall cavity can cause erroneous readings. The mixing of room air and air from within the wall cavity can lead to condensation, erroneous readings and sensor failure. To prevent these conditions, BAPI recommends sealing the conduit leading to the junction box, filling the junction box with fiberglass insulation or sealing the wall cavity.

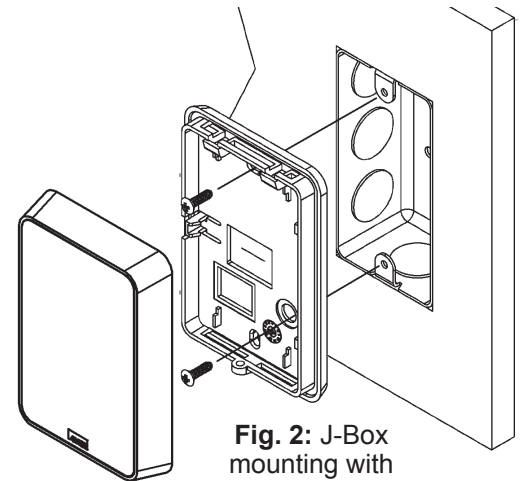

Fig. 2: J-Box mounting with standard base

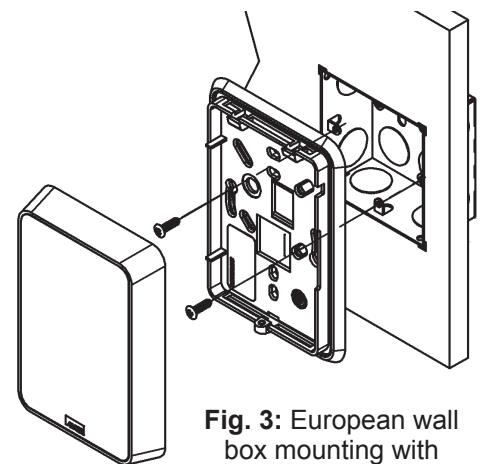

Fig. 3: European wall box mounting with 60mm base

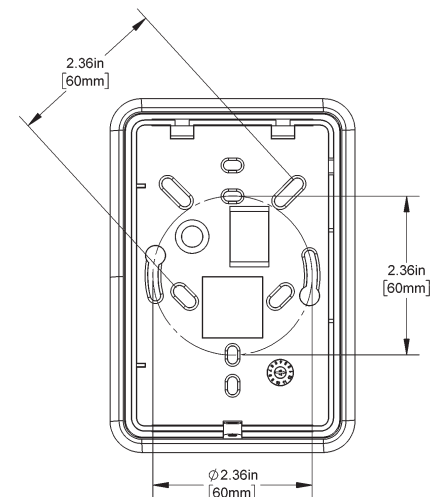

Fig. 4: 60mm mounting base dimensions

Specifications subject to change without notice.



# VOC Room Sensor in the BAPI-Stat "Quantum Prime" Style Enclosure

Installation and Operating Instructions

40697\_ins\_BSQPrime\_VOC

rev. 07/22/20

## Termination

BAPI recommends using twisted pair of at least 22AWG and sealant filled connectors for all wire connections. Larger gauge wire may be required for long runs. All wiring must comply with the National Electric Code (NEC) and local codes. Do NOT run this device's wiring in the same conduit as AC power wiring. BAPI's tests show fluctuating and inaccurate signals are possible when AC power wiring is in the same conduit as the signal lines. If you are experiencing any of these difficulties, please contact your BAPI representative.



BAPI recommends wiring the product with power disconnected. Proper supply voltage, polarity and wiring connections are important to a successful installation. Not observing these recommendations may damage the product and void the warranty.

Note: For proper operation, the jumper on PRG connector of J19 must not be installed on both legs.

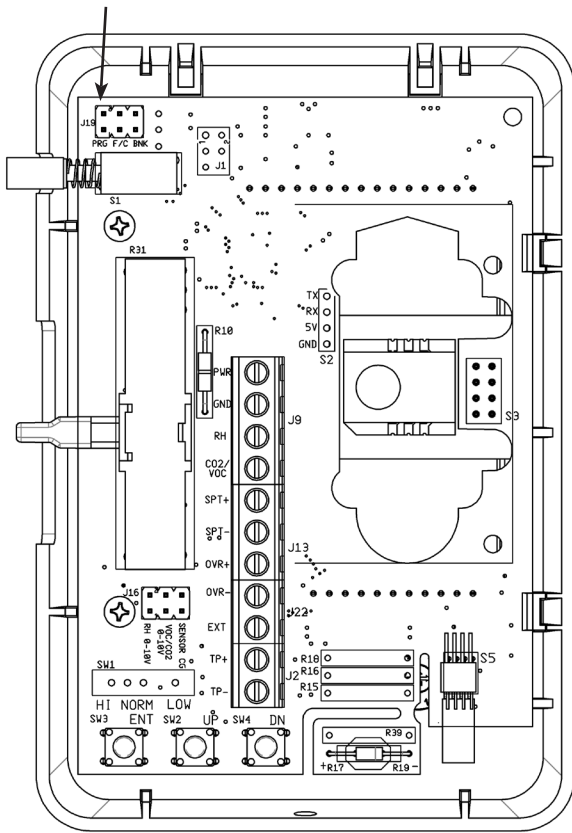

Fig. 5: Circuit Board

Terminal	Function
<b>PWR</b>	Power, referenced to GND (Ground). See Voltage Specifications above.
<b>GND</b>	To controller Ground (GND or Common).
<b>RH</b>	Voltage Output Humidity Signal referenced to the GND terminal.
<b>CO2/VOC</b>	Voltage Output VOC Signal (0 to 2,000ppm) referenced to the GND terminal.
<b>SPT+ &amp; SPT-</b>	Temperature Setpoint Output per order (resistive or voltage). Voltage output requires Common Ground, SPT- is referenced to the GND terminal.
<b>OVR+ &amp; OVR-</b>	Override output (Dry contact). The contact can be ordered as a momentary shunt across the sensor, momentary shunt across the setpoint, or as a separate momentary contact. If the unit is Common Ground, OVR- is referenced to the GND terminal.
<b>EXT</b>	External occupied LCD indicator is activated by logic LOW or ground at this terminal, referenced to the GND
<b>TP+ &amp; TP-</b>	Temperature Sensor Output (Resistive Only).
	When jumper is installed on J16 Sensor CG, TP- is connected to the GND terminal. It is recommended to wire TP+ and TP- as differential to prevent interference on GND from pulse readings on the VOC Sensor.

Note: Unit is not ready for operation until the 15 minute start-up time has elapsed.

## Optional Test and Balance Switch (SW1)

	Low: Will set sensor value low
	Norm: Sensor will operate normally
	High: Will set sensor value High

Sensor Type	Low Temp	High Temp
1000 Ω RTD	1.02K Ω (41.2°F)	1.15K Ω (101.5°F)
3000 Ω Thermistor	7.87K Ω (39.8°F)	1.50K Ω (106.8°F)
10K-2 Thermistor	30.1K Ω (34.9°F)	4.75K Ω (109.1°F)
10K-3 Thermistor	26.7K Ω (35.9°F)	5.11K Ω (108.4°F)
10K-3(11K) Thermistor	7.32K Ω (43.7°F)	3.65K Ω (105.2°F)

Specifications subject to change without notice.

## Optional Communications Jack Wiring

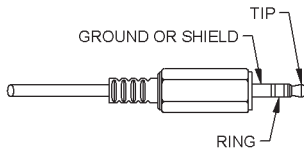

Table 1: C35 Wiring	
	Wire Color
Ground	Black
Tip	White
Ring	Red

C35 Communication Jack  
(Male jack shown for clarity)

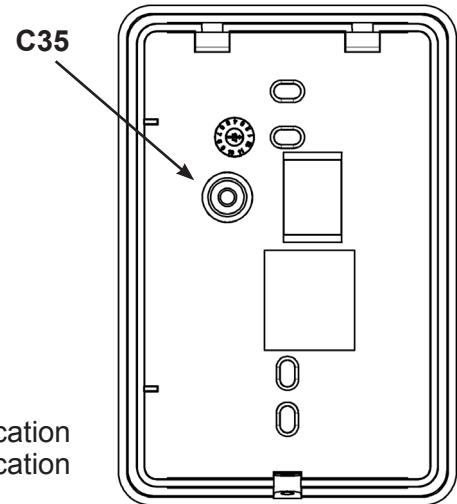

Fig. 6: Communication Jack Location

## User Operation

The display indicates VOC in equivalent CO<sub>2</sub> PPM, temperature in °F or °C, %RH, temperature setpoint in degrees °F or °C and override using the Human Icon.

The major display indicates the VOC in equivalent CO<sub>2</sub> PPM. The minor display indicates the temperature in °F or °C, %RH, and temperature setpoint in degrees °F or °C when present.

### Temperature Setpoint Slidepot:

Moving the slidepot enough to change the setpoint will display the setpoint on the minor LCD display if equipped with display. The setpoint temperature display will flash the digits indicating that setpoint is being changed.

### Override Button:

When the override button is pressed on display units, the Human Icon will display. A dry resistance of less than 1 ohm appears from the override output. Latching the Icon to show that the system is in override requires that a dry contact on your controller be used to connect terminal EXT to ground.

### VOC Level Indication via 3 Discrete LEDs:

The VOC level indication (in equivalent CO<sub>2</sub> PPM) is available via 3 discrete LEDs on the logo plate with green for good, yellow for fair and red for poor. The red LED will begin to flash when the unit exceeds 2,000 ppm, indicating that fresh air needs to be brought in.

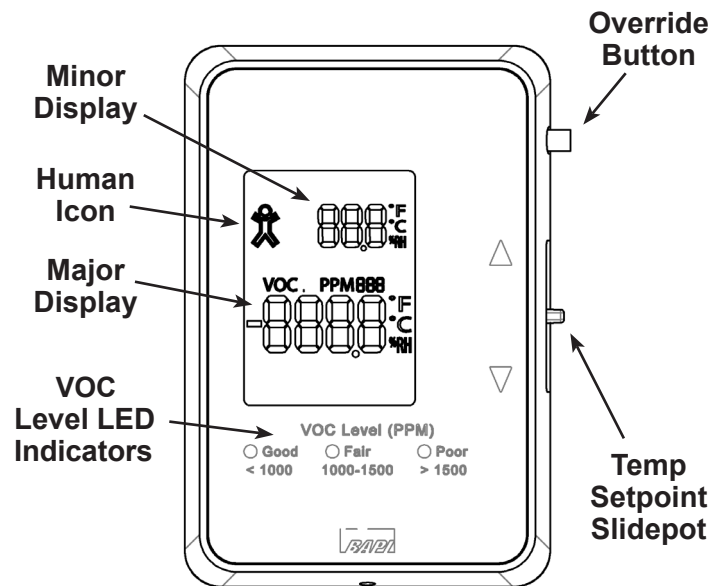

Fig. 7: VOC Unit Indicators  
(Shown above with all optional indicators)

Specifications subject to change without notice.



# VOC Room Sensor in the BAPI-Stat “Quantum Prime” Style Enclosure

Installation and Operating Instructions

40697\_ins\_BSQPrime\_VOC

rev. 07/22/20

## Optional Technician Adjustments

BAPI's VOC room sensor comes calibrated and ready to operate. In some installations the sensor may not match local instrumentation. The technician adjustment procedure allows °F or °C display units, temperature or humidity offsets or display information to be changed at any time.

### Removing Ground from Temperature Sensor

Some installations may experience erratic temperature readings due to increased power consumption when the VOC sensor element takes a reading. A possible remedy may be to float the temperature sensor as shown in Figs 8 and 9. Run wires directly from TP+ and TP- to the controller's analog input. The VOC/CO2 and RH jumpers are omitted for clarity.

### °F or °C Display Units

Figs 10 and 11 show the jumper positions for displayed values of Celsius or Fahrenheit degrees. The jumpers on pins PRG and BNK are omitted for clarity.

### Parameter Offsets & Display Information

Figs 12 and 13 show how to place the unit into field setup mode. Take the jumper from the BNK terminals and place it on the PRG terminals. The F/C jumper is omitted for clarity.

The major display should read P1.

Use the UP/DN buttons (See Fig 14) to select the desired page.

Press and release the ENT button to select the desired page.

Use the UP/DN buttons to adjust the desired value

Press and release the ENT button to save the change and return to the page display.

Adjust another page or place the jumper into normal operation.

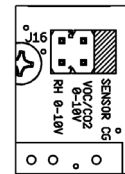

Fig. 8: Temp. Sensor Grounded

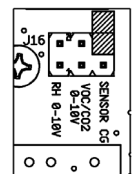

Fig. 9: Temp. Sensor Floating

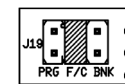

Fig. 10: °F

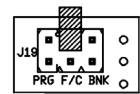

Fig. 11: °C

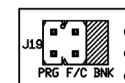

Fig. 12: Normal Operation

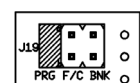

Fig. 13: Programming Setup

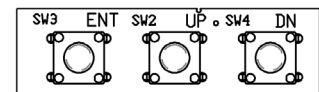

Fig. 14: Calibration Buttons

Programming Pages			
Parameter	Page	Adjustment	
Display Options	P1	Item	Display Action - VOC always shown in major display
		0	VOC Only
		1	VOC and Temperature
		2	VOC and %RH
		3	VOC, Temperature, and %RH (5 second rotation in minor display)
		4	VOC, Temperature Setpoint when active
		5	VOC, Temperature, and Temperature Setpoint when active
		6	VOC, %RH, and Temperature Setpoint when active
	7	VOC, Temperature, %RH, and Temperature Setpoint when active (5 second rotation in minor display)	
Temperature Offset	P2	±5° in 0.1° increments	
Humidity Offset	P3	±5%RH in 0.1%RH increments	
VOC Offset	P4	±100ppm in 1ppm increments	

Specifications subject to change without notice.

## Output Selection

The VOC outputs may be field configured for 0 to 5 VDC or 0 to 10 VDC outputs at any time. Set the jumpers on J16 as shown in Figs 15 and 16.

The humidity outputs may be field configured for 0 to 5, 1 to 5, 0 to 10 or 2 to 10 VDC outputs at any time. Set the jumpers on J16 as shown in Figs 17 and 18.

**Note:** The jumpers on the pins not being described are omitted for clarity on the figures at right.

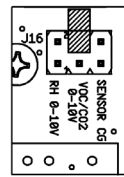

**Fig. 15:**  
VOC Output  
0 to 5 VDC

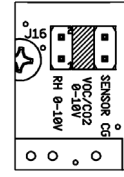

**Fig. 16:** VOC  
Output 0 to  
10 VDC

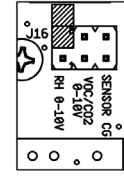

**Fig. 17:** %RH  
Output 0 to 5  
or 1 to 5 VDC

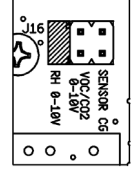

**Fig. 18:** %RH  
Output 0 to 10  
or 2 to 10 VDC

## Sensor Start-Up

Do not set the control parameter to a VOC limit until the VOC sensor has been installed for a week. The first few days of install may provide different readings compared to several days later.

At each power up, the sensor enters the start-up period for 15 minutes. The major display will show the current temperature and the minor display will show 123 for the first 15 seconds. The VOC output and display will follow the timing shown in Fig 18. Start-up time for the humidity output is 30 seconds, while the outputs for temperature and temperature setpoint are available immediately.

During the start-up period an optional verification/commissioning test, described below, may be performed. This test is not mandatory, it is necessary only if building commissioning requires sensor verification or if verification of VOC output is required for later troubleshooting.

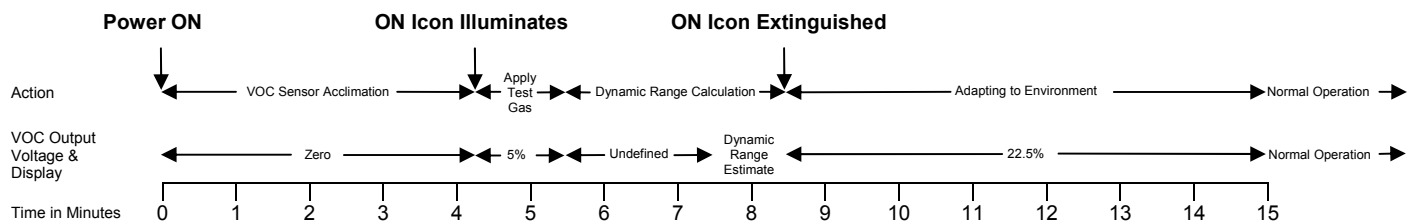

**Fig 19:** Sensor Start-up Timeline

## Optional Sensor Performance Verification and Commissioning

BAPI's VOC sensor contains an adaptive, self adjusting, Volatile Organic Compound (VOC) sensor element that provides a CO<sub>2</sub> equivalent control signal output. When incorporated into a control strategy based on ASHRAE's Demand Control Ventilation algorithm, ventilation using this sensor will achieve true indoor air quality and not just CO<sub>2</sub> dilution.

The fundamental performance criterion of the VOC sensor element is its dynamic sensing range. The VOC sensor element requires a minimum dynamic range of 3 for proper operation. During BAPI's verification/commissioning test, the dynamic range is tested and displayed.

BAPI recommends installing the sensor and powering it for at least 48 hours before the first verification test is performed. BAPI further recommends ventilating the space such that the sensor reads 750 ppm CO<sub>2</sub> equivalent before any verification test is performed. Wait at least one hour before repeating the test.

### 1. Start Automatic Verification/Commissioning Test

- A. Remove sensor power for at least one minute and reapply. The VOC sensor will set the VOC output to zero volts. Display models will indicate 0.0 on the major display and CMS, short for commissioning, on the minor display. (Power ON in Fig 19)
- B. Wait four minutes fifteen seconds.
- C. The VOC sensor will set the VOC output voltage to 5% of full scale (0.25 VDC for 0 to 5 VDC, 0.5 VDC for 0 to 10 VDC or 2.4 VDC for 2 to 10 VDC outputs). Display units will illuminate the ON icon and set the major display to 1.0.
- D. The visual indication and the 5% output voltage confirms that the VOC sensor is in its verification/commissioning test. (Apply Test Gas period in Fig 19)

Continued on next page...

Specifications subject to change without notice.

## Optional Sensor Performance Verification and Commissioning continued...

### 2. Apply Verification Stimulus

- A. Apply the stimulus gas during the first minute after the sensor illuminates the ON icon (See Stimulus Preparation and Application).
- B. Read and record the VOC output voltage or Major LCD display approximately 2 to 4 minutes following the stimulus gas application to determine the dynamic range measurement. (Dynamic Range Estimate period in Fig 19)
- C. When the dynamic range estimate period is complete the ON icon will be extinguished.

### 3. Termination of Verification Mode

- A. For the last 7 minutes of the start-up period the sensor adapts to its ambient environment. The VOC sensor will maintain its output voltage at 450 ppm CO2 equivalent. Display units will show 450 ppm equivalents.
- B. At 15 minutes the VOC sensor will terminate the start-up period and begin normal operation.
- C. The VOC output will now report the VOCs present as CO2 equivalents.

### 4. Result Analysis and Recommendations

- A. The VOC algorithm requires a dynamic range of greater than 30% for proper operation. Sensors reporting dynamic range of 30% or less should be considered for replacement. (See Fig 21)

## Stimulus Preparation and Application

Place 50ml of 70% minimum Isopropyl Alcohol (customer supplied) into a 200ml glass bottle (2oz in an 8oz glass bottle) with stopper and allow to reach room temperature (65° to 80°F, 18° to 27°C), a minimum of 15 minutes.

- 1. Using a medical grade syringe, remove the stopper from the alcohol bottle, place the tip of the syringe at least half-way into the bottle and withdraw a 60 ml sample of the ALCOHOL VAPOR. (NO LIQUID)
- 2. Replace the stopper on the alcohol bottle.
- 3. Place the end of the syringe -
  - A. Over, or into the top ventilation slot of the VOC monitor's housing for room versions.
  - B. Into a knockout opening or directly into the aspiration probe's top hole for duct mount versions.
- 4. Empty the syringe into the sensor using one continuous motion.

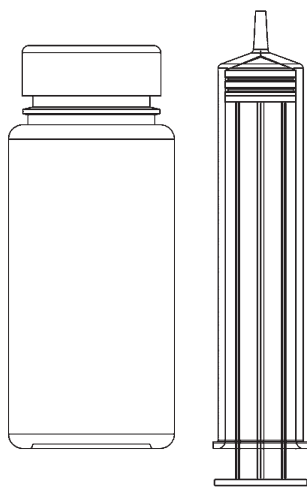

Fig 20: Alcohol Bottle and Syringe

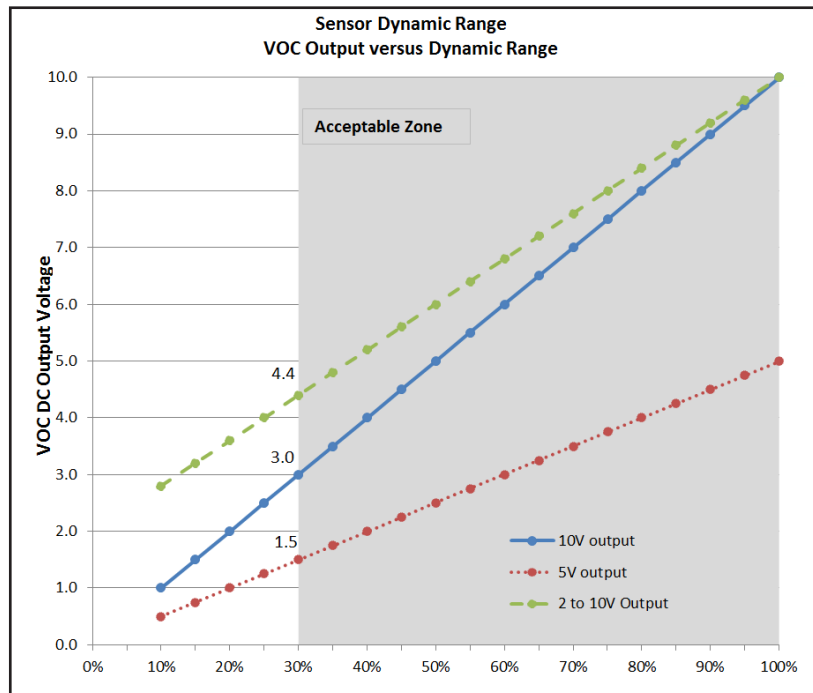

Fig 21: Acceptable Dynamic Range Output

Specifications subject to change without notice.



# VOC Room Sensor in the BAPI-Stat “Quantum Prime” Style Enclosure

Installation and Operating Instructions

40697\_ins\_BSQPrime\_VOC

rev. 07/22/20

## Diagnosics

<b>POSSIBLE PROBLEMS:</b>	<b>POSSIBLE SOLUTIONS:</b>
General troubleshooting	<p>Determine that the input is set up correctly in the controller’s and building automation software.</p> <p>Check wiring at the sensor and controller for proper connections.</p> <p>Check for corrosion at either the controller or the sensor. Clean off the corrosion, re-strip the interconnecting wire and reapply the connection. In extreme cases, replace the controller, interconnecting wire and/or sensor.</p> <p>Label the terminals that the interconnecting wires are connected to at the sensor end and the controller end. Disconnect the interconnecting wires from the controller and the sensor. With the interconnecting wires separated at both ends measure the resistance from wire-to-wire with a multimeter. The meter should read greater than 10 Meg-ohms, open or OL depending on the meter you have. Short the interconnecting wires together at one end. Go to the other end and measure the resistance from wire-to-wire with a multimeter. The meter should read less than 10 ohms (22 gauge or larger, 250 feet or less). If either test fails, replace the wire.</p> <p>Check power supply/controller voltage supply</p> <p>Disconnect sensor and check power wires for proper voltage (see specs on pg 1)</p>
Incorrect VOC	<p>Wait 15 minutes after a power interruption.</p> <p>Check all software parameters</p> <p>Determine if the sensor is exposed to an external environment different from the room (conduit draft)</p>
Incorrect Humidity	<p>Check all software parameters</p> <p>If available, check the sensor against a calibrated instrument such as a hygrometer</p> <p>Determine if the sensor is exposed to an external environment different from the room (conduit draft)</p>
Incorrect Temperature	<p>Determine that the temperature sensor’s wires are connected to the correct controller input terminals and are not loose.</p> <p>Check the wires at the sensor and controller for proper connections.</p> <p>Make sure that the sensor leads are not touching one another.</p> <p>Determine if the sensor is exposed to an external environment different from the room (conduit or wall cavity draft)</p> <p>Compare the actual temperature of the room to the resistance of the temperature sensor inside the VOC unit. Measure the physical temperature at the temperature sensor’s location using an accurate temperature standard. Disconnect the temperature sensor wires (Terminals TP+ &amp; TP-) inside the VOC unit and measure the temperature sensor’s resistance across the sensor output pins with an ohmmeter. Put the ohmmeter’s black lead on Terminal TP- and the red lead on Terminal TP+. Compare the temperature sensor’s resistance to the appropriate temperature sensor table on the BAPI website (See below). If the measured resistance differs from the temperature table by more than 5%, call BAPI technical support. Don’t forget to reconnect the wires.</p> <p><b>How to Find Temperature Sensor Resistance</b></p> <p>Find BAPI’s web site at <a href="http://www.bapivac.com">www.bapivac.com</a>; click on “Resource Library” and “Sensor Specs”, then click on the sensor type you have.</p>

Specifications subject to change without notice.